

SOLUTION

BENDING



HFE 3i5012



ERGONOMIC, NETWORK COMPATIBLE, COMPACT AND HIGHLY PRODUCTIVE

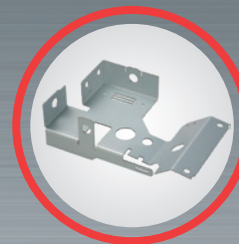
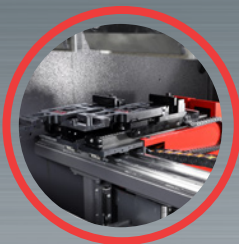

AMADA

HFE 3i 5012

ERGONOMIC, NETWORK COMPATIBLE, COMPACT AND HIGHLY PRODUCTIVE

SMART PROCESSING OF SMALL COMPONENTS

Based on the success of the HFE3i series, this new edition to the range, offers a compact, ergonomic and high productivity option. Network compatible, with a 3D control, the HFE3i-5012 is a flexible solution for small parts with varying processes and batch sizes.

ERGONOMICS - The operator is at the heart of the 5012 concept. Ergonomic solutions are designed to make the bend process comfortable and fast. The solution, offers the operator all the comfort, space and tools to be highly productive throughout the day.

PRODUCTIVITY - Thanks to the high performance of upper beam and the AMADA patented FAST finger (Finger with Active Safety Technology), the HFE3i-5012 is a highly productive solution for small parts processing.



Photograph may include optional equipment

EQUIPMENT

AKAS 5



The latest AKAS security system solution (AKAS 5) offers the highest level of safety with an increased performance due to easier set-up.

HAND WHEEL



Manual adjustments of all axes are easily done with the hand wheel.

DIGIPRO



This electronic device uses wireless technology to transmit the measured angle to the NC. The machine then compensates to provide a precise bend angle.

MAIN FUNCTIONS

1 ERGONOMIC

FAST, COMFORTABLE OPERATION

The working environment has been organised with features that support the operator's activity. They can work with higher comfort, higher speed and, therefore, higher productivity with less effort.

- Front table with adjustable height, can be folded away if necessary
- Ergonomic chair with adjustable height and backrest inclination
- Footrest for operation when sitting, retractable when standing
- Drawers: 3 on each side, equipped with specific inserts to store tooling
- Work place lighting kit

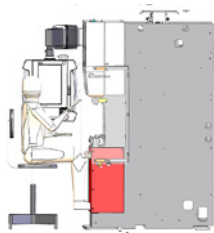

2 FAST, FLEXIBLE AND ACCURATE

5-AXIS BACK GAUGE

High speed and dynamic back gauge guarantees fast positioning for increased productivity

- With Delta X for effective and reliable gauging
- FAST: The back gauge with active security feature allows increased productivity and process safety with low impact force and maximum speed
- U-Shape Finger (option): Special finger shape for smart gauging of complex part shape. Finger position is automatically calculated by AMNC 3i or VPSS 3i.

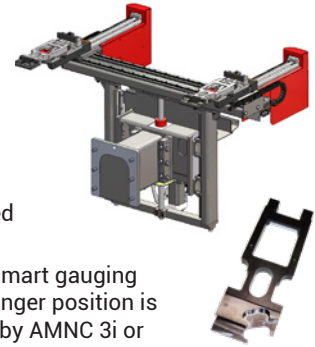

3 NETWORK COMPATIBLE

SMART PROGRAMMING

The network ready AMNC 3i numerical control allows for offline programming, digital integration and is compatible with Industry 4.0.

- A user-friendly and easy to use 18.5 inch multi-touch screen removes the need for an external keyboard, offering multiple programming options.
- The use of offline programs allows to reduce set-up time and increase machine efficiency.



The bending CAM software VPSS 3i BEND, automatically selects tools, creates tool layouts and bend sequences.



4 FLEXIBLE TOOLING SOLUTIONS

CLAMPING AND TOOLS

- SGRIP (standard)
- R-GRIP (option)
- Hydraulic clamp (option)
- Dedicated range of die holders

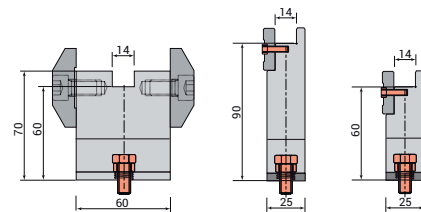

- AFH tools



5 COMPACT AND POWERFUL SOLUTION

FRAME AND UPPER BEAM

The increased open height of the frame results in the optimum solution for all tooling types, allowing deeper box bending.

The new lower beam with crowning function, operator ergonomics and narrower dimensions provide high process flexibility.

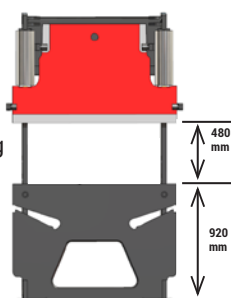

6 GREEN AND RELIABLE

INVERTER

The Eco-drive system continually monitors and self-adjusts bending requirements – providing benefits such as less energy usage, reduced maintenance, less oil consumption, lower noise levels and increased reliability.

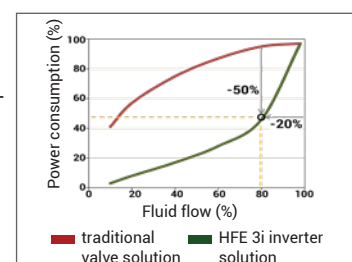

MACHINE DIMENSIONS

Units: mm

HFE3i-5012
(L*) 2653 x (W**) 2267 x (H) 2420

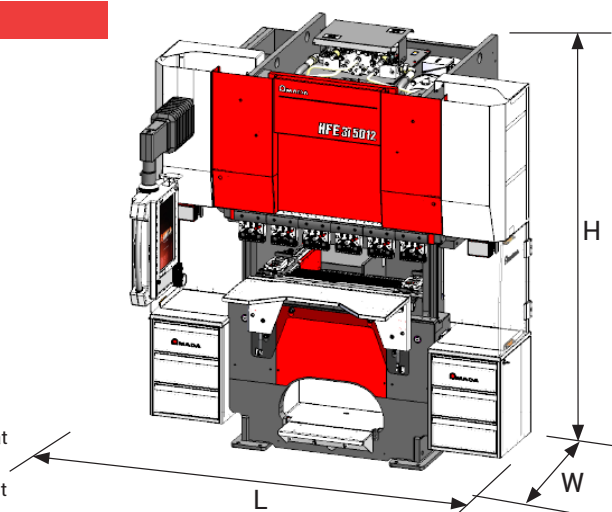

*Length includes the NC with the arm turned at the maximum on the exterior

** Width includes the NC with the arm turned at the maximum forward

MACHINE SPECIFICATIONS

HFE3i-5012		
Bending capacity	kN	500
Beam length	mm	1270
Distance between frames	mm	1035
Throat depth	mm	100
Open height	mm	480
Upper beam stroke	mm	150
Working height	mm	920
Power consumption (only pump motor)	kW	5.5
Oil capacity	l	85
Approach speed (with additional protection option)	mm/s	220
Bending speed	mm/s	25*
Return speed	mm/s	220
Minimum increment	mm	0.01
Positioning accuracy	mm	+/- 0.005
Machine mass	kg	3550

*max load 350 kN and depending by V-die

BACK GAUGE SPECIFICATIONS

5-AXIS BACK GAUGE				
		X axis	R axis	Z axis
Operating stroke	mm	300	185	720
Speed	mm/s	1000	200	1000
Accuracy	mm	+/- 0.1	+/- 0.2	+/- 1

The specifications, appearance and equipment are subject to change without notice due to improvement.



For Your Safety

Please read the user manual before use. Before using this machine, please familiarise yourself with the risks.

The use of this product requires appropriate risk prevention measures depending on the type of work to be performed. The safety devices recommended by AMADA are supplied as standard for proper use with regard to EC conformity.

The official name of the machine described in this brochure is HFE3i-5012. Please use this reference when contacting authorities to apply for financing, installation or exporting. The machine name may contain a hyphen for easier reading.

Safety devices have been removed in some photos used in this brochure.

AMADA UK LTD.

Spennells Valley Road,
Kidderminster,
Worcestershire DY10 1XS
United Kingdom
Tel: +44 (0)1562 749500
Fax: +44 (0)1562 749510
www.amada.co.uk

AMADA SA

Paris Nord II
96, avenue de la Pyramide
93290 Tremblay en France
France
Tél : +33 (0)1 49 90 30 00
Fax : +33 (0)1 49 90 31 99
www.amada.fr

AMADA GmbH

Amada Allee 1
42781 Haan
Germany
Tel: +49 (0)2104 2126-0
Fax: +49 (0)2104 2126-999
www.amada.de

AMADA ITALIA S.r.l.

Via Amada I., 1/3
29010 Pontenure
(Piacenza)
Italia
Tel: +39 0523 872111
Fax: +39 0523 872101
www.amada.it

